

Server node

Client node

socket
bind
listen

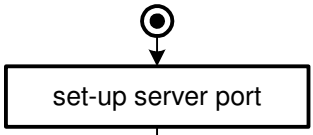

accept

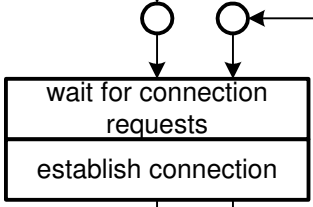

read
write

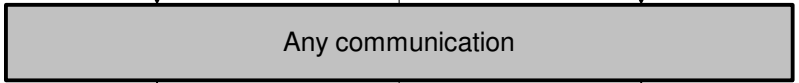

close

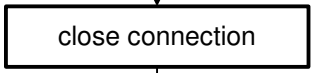

socket
connect

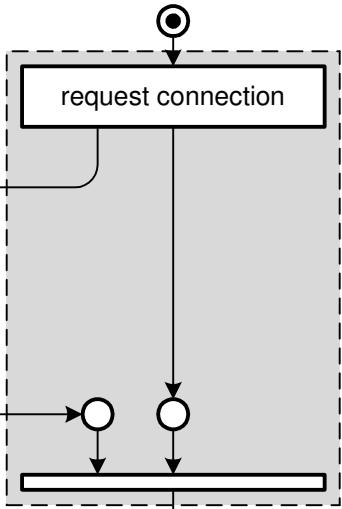

read
write

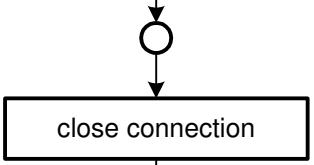

close